

Stage I  
**Light House**  
 Jay Worden - CRO

**Stage Designer:** Nationals Design Team  
**Scoring Method:** Comstock  
**Targets:** 7 IPSC – Best 2/paper  
**Rounds/Points:** 14 rounds, 70 points  
**Start/Stop:** Audible - Last Shot

**Penalties:**  
 Per current edition of USPSA Rule Book.

**Start Position:**  
 Standing at door, strong hand on doorknob, flashlight on wrist, gun loaded in ready condition and holstered.

**Procedure:**  
 Upon start signal, engage all targets as visible while inside house.

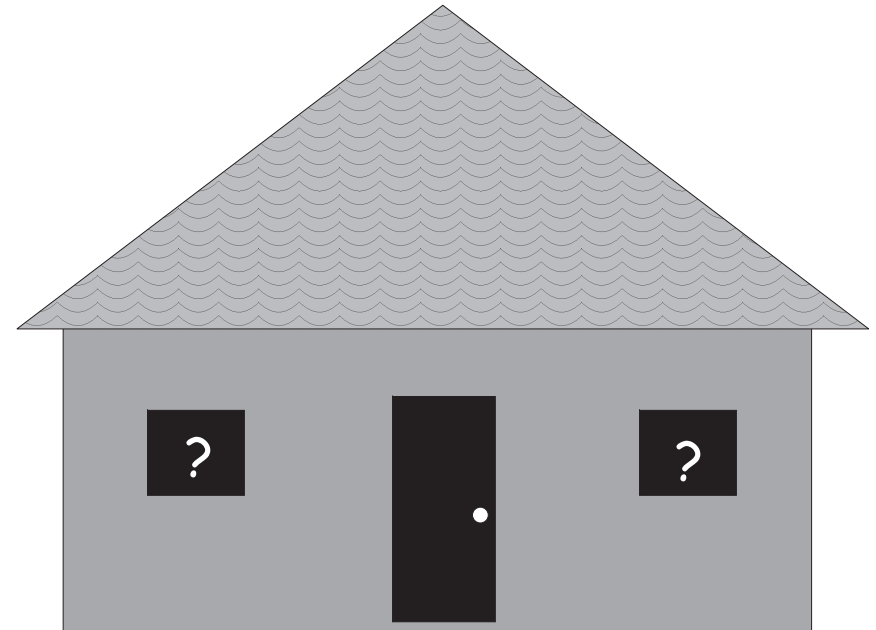

**PERSONAL STAGE DATA**

Points: \_\_\_\_\_ Stage Points: \_\_\_\_\_  
 Time: \_\_\_\_\_ Stage Percent: \_\_\_\_\_  
 Hit Factor: \_\_\_\_\_ Stage Place: \_\_\_\_\_  
 High Hit Factor: \_\_\_\_\_ HHF Shot by: \_\_\_\_\_

Stage 2  
**Full Throttle**  
 Carl Schmidt - CRO

**Stage Designer:** Nationals Design Team  
**Scoring Method:** Comstock  
**Targets:** 13 IPSC, 3 PP – Best 2/paper, Steel 1 KD = 1 “A”  
**Rounds/Points:** 29 rounds, 145 points  
**Start/Stop:** Audible - Last Shot

**Penalties:**  
 Per current edition of USPSA Rule Book.

**Start Position:**  
 Heels on X’s with hands naturally at sides, gun loaded in ready condition and holstered.

**Procedure:**  
 Upon start signal, engage all targets as visible from the area indicated.

**Notes:**  
 PP3 activates gravity turner T1 which disappears.

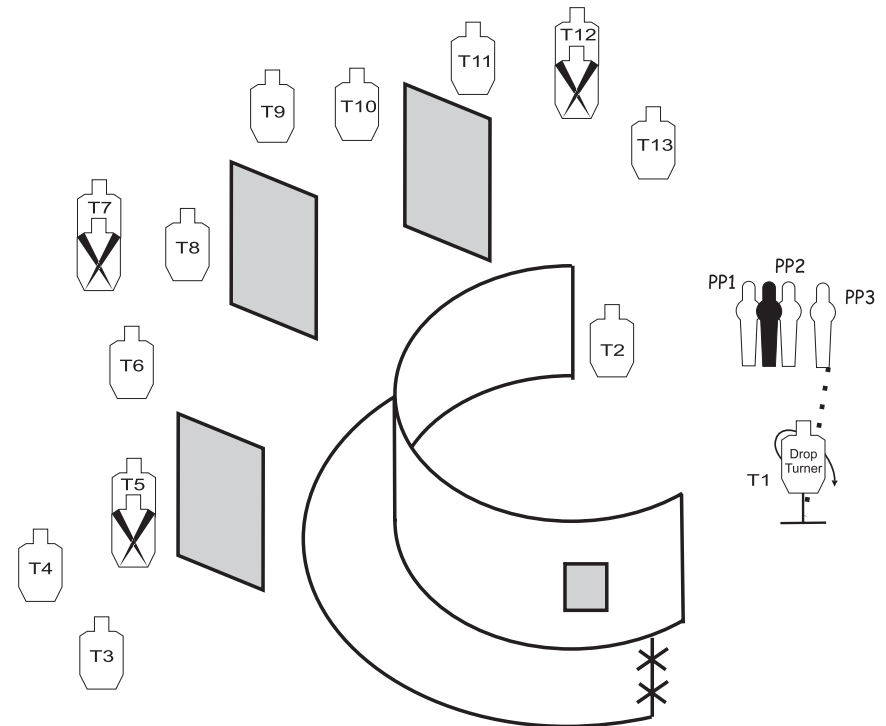

**PERSONAL STAGE DATA**

Points: \_\_\_\_\_ Stage Points: \_\_\_\_\_  
 Time: \_\_\_\_\_ Stage Percent: \_\_\_\_\_  
 Hit Factor: \_\_\_\_\_ Stage Place: \_\_\_\_\_  
 High Hit Factor: \_\_\_\_\_ HHF Shot by: \_\_\_\_\_

Stage 3  
**Jump Back**  
 Ken Kempker - CRO

**Stage Designer:** Nationals Design Team  
**Scoring Method:** Comstock  
**Targets:** 8 IPSC, 7 PP – Best 2/paper Steel: 1 KD = 1 "A"  
**Rounds/Points:** 23 rounds, 115 points  
**Start/Stop:** Audible - Last Shot

**Penalties:**  
 Per current edition of USPSA Rule Book.

**Start Position:**  
 Palms on X's, gun loaded in ready condition and holstered.

**Procedure:**  
 Upon start signal, engage all targets as visible, from the area indicated.

**Note:**  
 PP1 activates drop out T2, PP2 activates Max Trap T7, PP3 activates Max Trap T8.

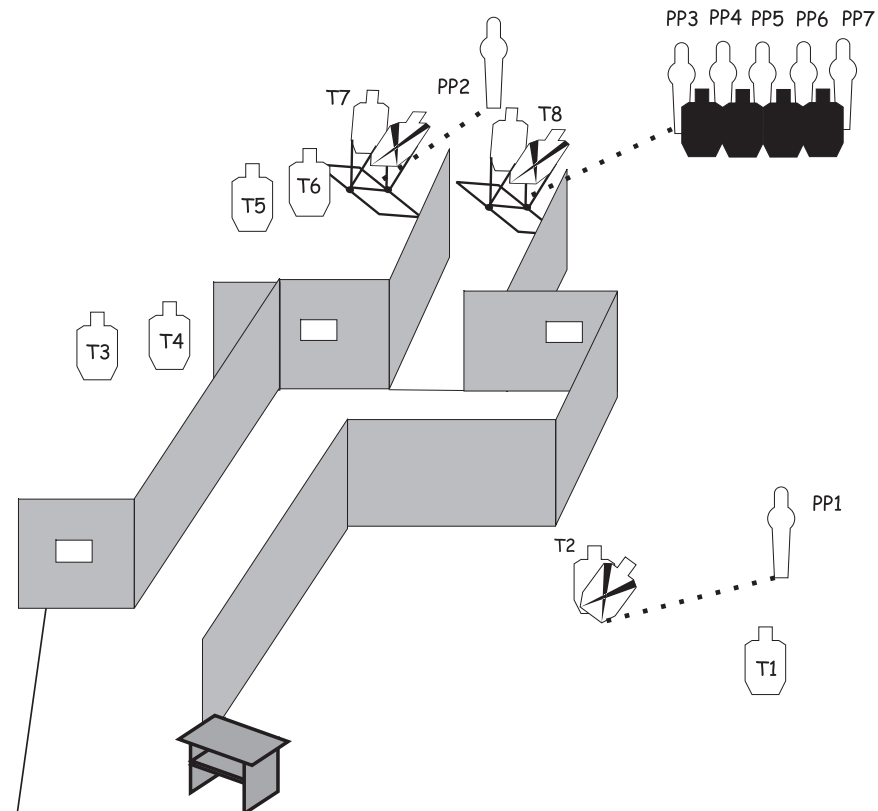

**PERSONAL STAGE DATA**

Points: \_\_\_\_\_ Stage Points: \_\_\_\_\_  
 Time: \_\_\_\_\_ Stage Percent: \_\_\_\_\_  
 Hit Factor: \_\_\_\_\_ Stage Place: \_\_\_\_\_  
 High Hit Factor: \_\_\_\_\_ HHF Shot by: \_\_\_\_\_

Stage 4  
**That's Fast**  
 Chris Thomas - CRO



*Brazos Custom Gunworks*  
 WWW.BRAZOSCUSTOM.COM 1911STORE.COM

**Stage Designer:** Nationals Design Team  
**Scoring Method:** Comstock  
**Targets:** 5 IPSC – Best 2/paper  
**Rounds/Points:** 10 rounds, 50 points  
**Start/Stop:** Audible - Last Shot

**Penalties:**  
 Per current edition of USPSA Rule Book.

**Start Position:**  
 Strong hand on door knob, weak hand naturally at side, gun loaded in ready condition and holstered.

**Procedure:**  
 Upon start signal, engage all targets as visible from the area indicated.

**Notes:**  
 Opening door activates gravity turner T3, which disappears.

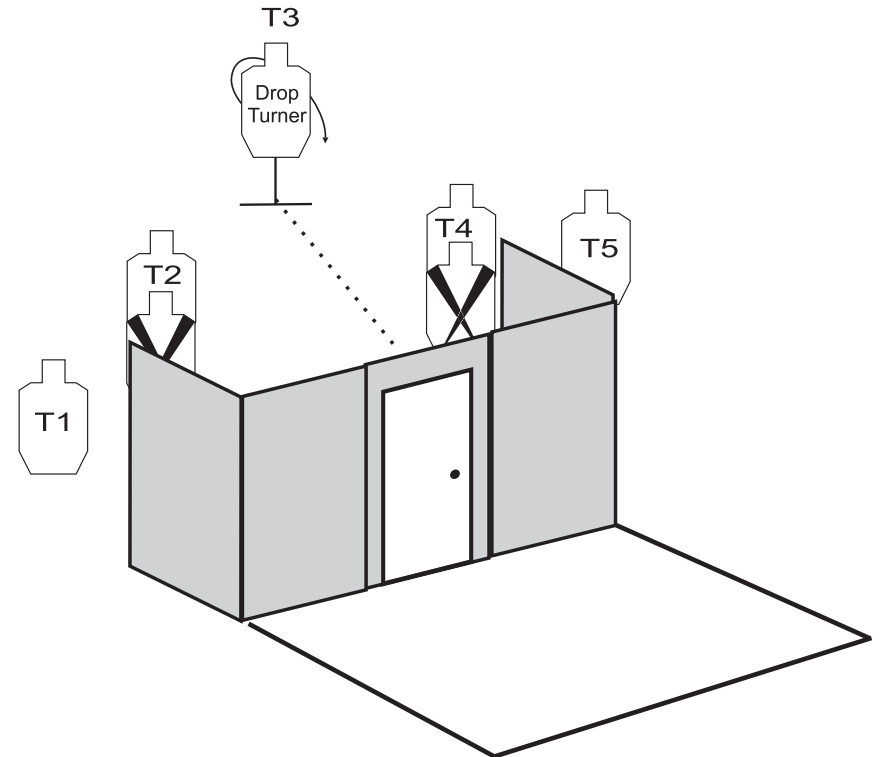

**PERSONAL STAGE DATA**

Points: \_\_\_\_\_ Stage Points: \_\_\_\_\_  
 Time: \_\_\_\_\_ Stage Percent: \_\_\_\_\_  
 Hit Factor: \_\_\_\_\_ Stage Place: \_\_\_\_\_  
 High Hit Factor: \_\_\_\_\_ HHF Shot by: \_\_\_\_\_

Stage 5  
**Junk In The Trunk**  
 J. J. Powell - CRO

**Stage Designer:** Nationals Design Team  
**Scoring Method:** Comstock  
**Targets:** 7 IPSC Classic  
**Rounds/Points:** 14 rounds, 70 points  
**Start/Stop:** Audible - Last Shot

**Penalties:**  
 Per current edition of USPSA Rule Book.

**Start Position:**  
 Hands on lounge arms, feet on lounge seat, shoulders against back of lounge, gun loaded in ready condition and placed in trunk.

**Procedure:**  
 Upon start signal, engage all targets as visible from the area indicated.



**Smith & Wesson**

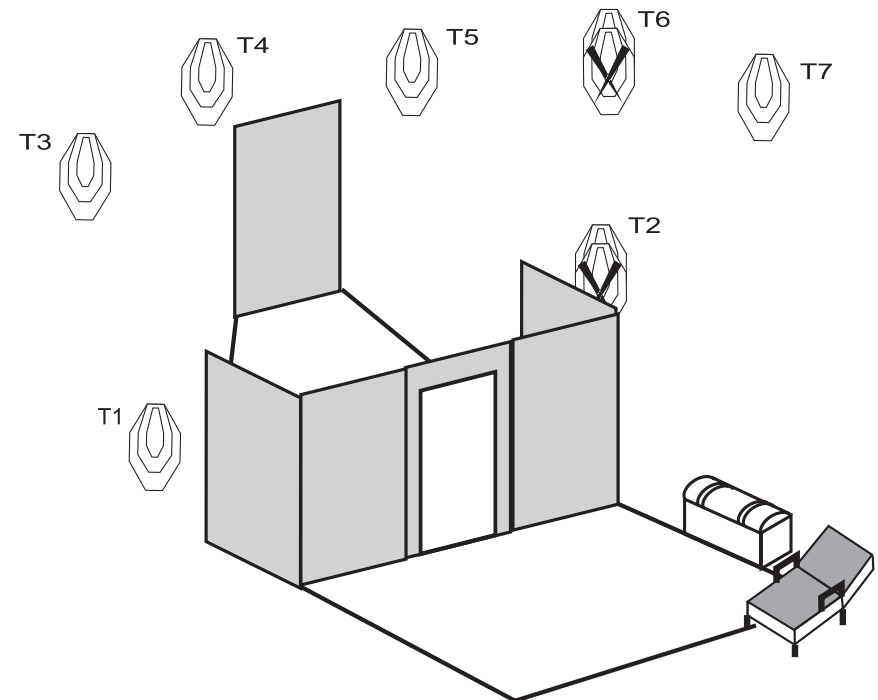

**PERSONAL STAGE DATA**

Points: \_\_\_\_\_ Stage Points: \_\_\_\_\_  
 Time: \_\_\_\_\_ Stage Percent: \_\_\_\_\_  
 Hit Factor: \_\_\_\_\_ Stage Place: \_\_\_\_\_  
 High Hit Factor: \_\_\_\_\_ HHF Shot by: \_\_\_\_\_

Stage 6  
**Loami Shuffle**  
 Bill Quintana - CRO

**Stage Designer:** Nationals Design Team  
**Scoring Method:** Comstock  
**Targets:** 7 IPSC, 2 PP – Best 2/paper Steel: 1 KD = 1 "A"  
**Rounds/Points:** 16 rounds, 80 points  
**Start/Stop:** Audible - Last Shot

**Penalties:**  
 Per current edition of USPSA Rule Book.

**Start Position:**  
 Hands on X's, toes touching board, gun loaded in ready condition and holstered.

**Procedure:**  
 Upon start signal, engage all targets as visible from the area indicated.

**Notes:**  
 PP1 activates gravity turner T1 which disappears.

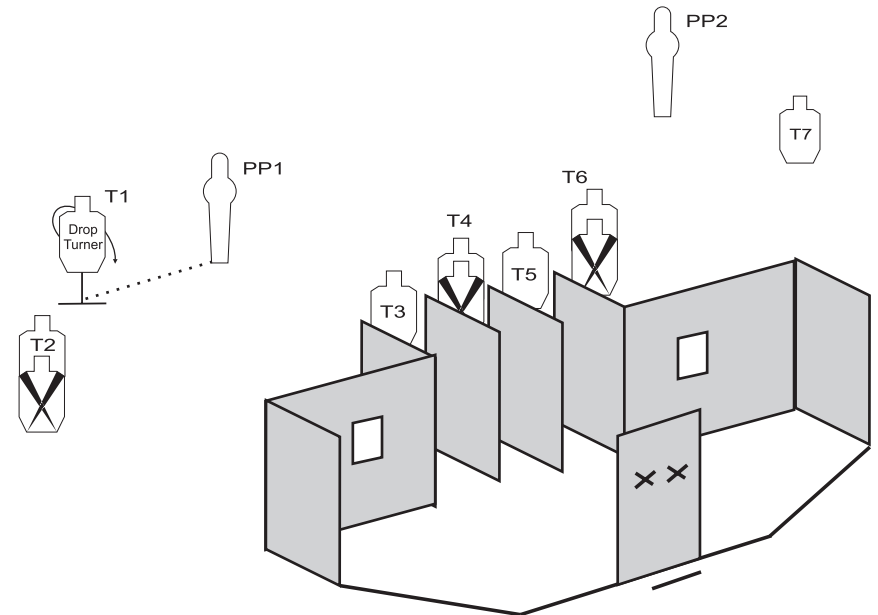

**PERSONAL STAGE DATA**

Points: \_\_\_\_\_ Stage Points: \_\_\_\_\_  
 Time: \_\_\_\_\_ Stage Percent: \_\_\_\_\_  
 Hit Factor: \_\_\_\_\_ Stage Place: \_\_\_\_\_  
 High Hit Factor: \_\_\_\_\_ HHF Shot by: \_\_\_\_\_

Stage 7  
**Drop Box**  
 Ed Putnam - CRO

**Stage Designer:** Nationals Design Team  
**Scoring Method:** Comstock  
**Targets:** 2 IPSC Classic, 4 PP— Best 2/paper, Steel: 1 KD = 1 "A"  
**Rounds/Points:** 8 rounds, 40 points  
**Start/Stop:** Audible - Last Shot

**Penalties:**  
 Per current edition of USPSA Rule Book.

**Start Position:**  
 Standing with both hands on package, facing up range, package in mail slot.  
 Gun loaded in ready condition and holstered.

**Procedure:**  
 Upon start signal, engage all targets as visible from the area indicated.

**Note:**  
 PP1 activates drop-out T1. PP4 activates drop-out T2.

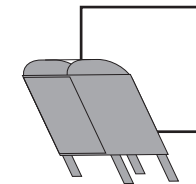
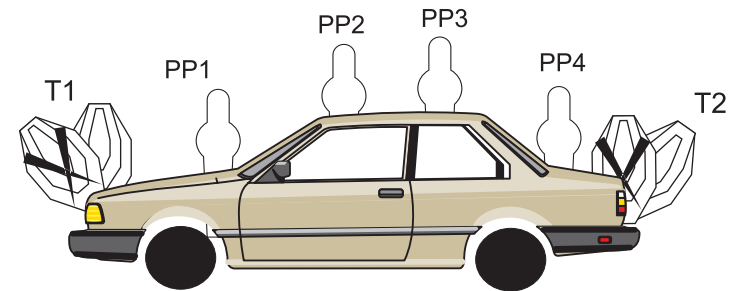

**PERSONAL STAGE DATA**

Points: \_\_\_\_\_ Stage Points: \_\_\_\_\_  
 Time: \_\_\_\_\_ Stage Percent: \_\_\_\_\_  
 Hit Factor: \_\_\_\_\_ Stage Place: \_\_\_\_\_  
 High Hit Factor: \_\_\_\_\_ HHF Shot by: \_\_\_\_\_

Stage 8  
**Peep Shot**  
 Keith Oltman - CRO

**Stage Designer:** Nationals Design Team  
**Scoring Method:** Comstock  
**Targets:** 8 rounds, 40 points  
**Rounds/Points:** 2 IPSC, 4 PP– Best 2/paper, Steel: 1 KD = 1 "A"  
**Start/Stop:** Audible - Last Shot

**Penalties:**  
 Per current edition of USPSA Rule Book.

**Start Position:**  
 Standing in box, hands naturally at sides, gun loaded in ready condition and holstered.

**Procedure:**  
 Upon start signal, engage all targets as visible from the area indicated.

**Notes:**  
 PP2 activates swinger T1. PP3 activates swinger T2.

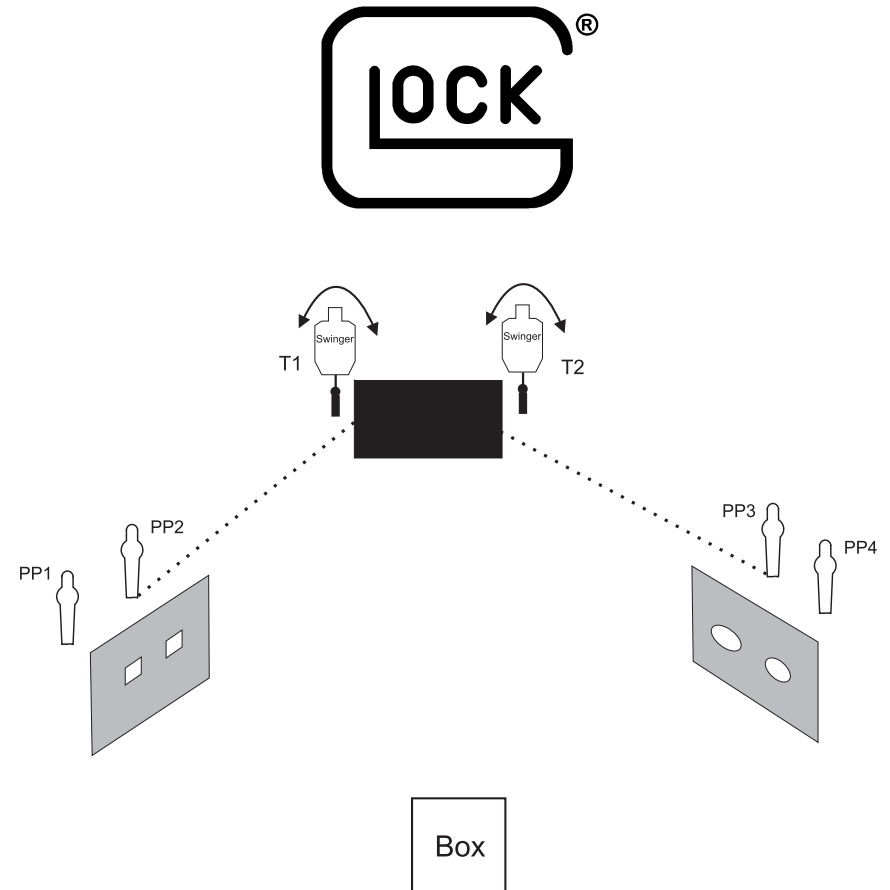

**PERSONAL STAGE DATA**

Points: \_\_\_\_\_ Stage Points: \_\_\_\_\_  
 Time: \_\_\_\_\_ Stage Percent: \_\_\_\_\_  
 Hit Factor: \_\_\_\_\_ Stage Place: \_\_\_\_\_  
 High Hit Factor: \_\_\_\_\_ HHF Shot by: \_\_\_\_\_

Stage 9  
**Room With A View**  
 George Jones - CRO

**Stage Designer:** Nationals Design Team  
**Scoring Method:** Comstock  
**Targets:** 9 IPSC, 4 PP – Best 2/paper, Steel: 1 KD = 1 “A”  
**Rounds/Points:** 22 rounds, 110 points  
**Start/Stop:** Audible - Last Shot

**Penalties:**  
 Per current edition of USPSA Rule Book.

**Start Position:**  
 Heels on X’s, gun loaded in ready condition and holstered.

**Procedure:**  
 Upon start signal, engage all targets as visible from the area indicated.

**Notes:**  
 PP4 activates gravity turner T8, which disappears.

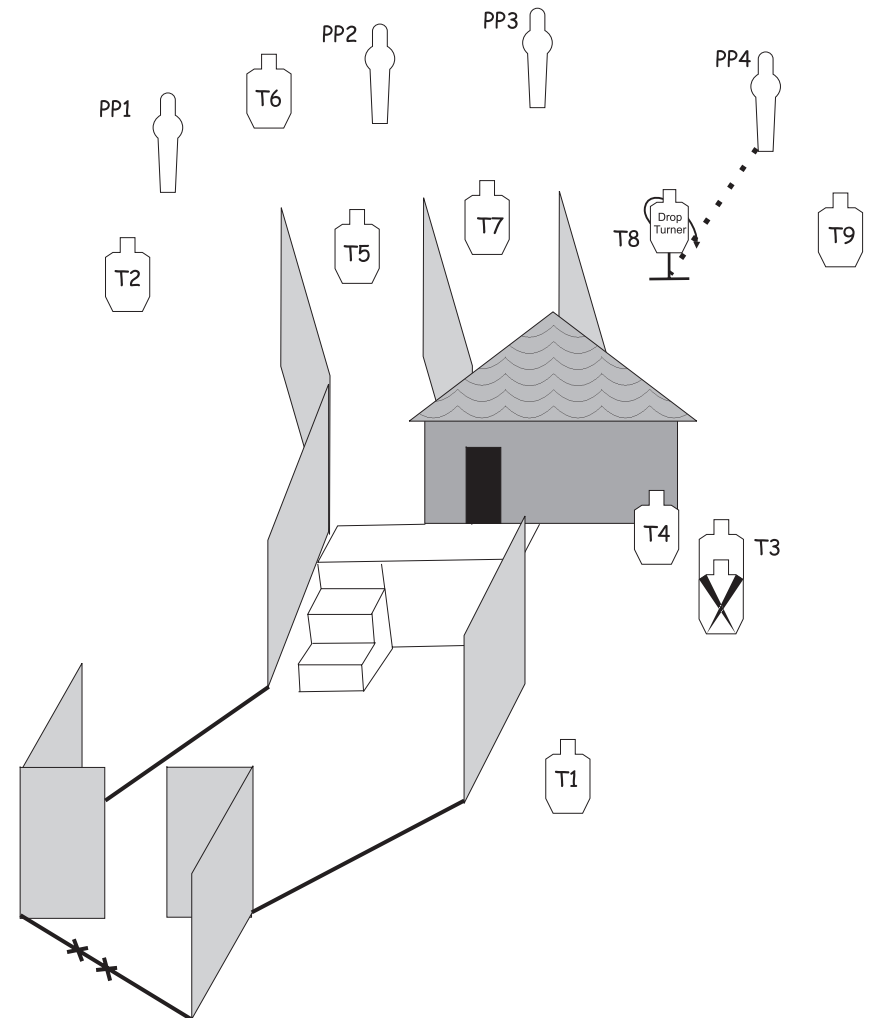

**PERSONAL STAGE DATA**

Points: \_\_\_\_\_ Stage Points: \_\_\_\_\_  
 Time: \_\_\_\_\_ Stage Percent: \_\_\_\_\_  
 Hit Factor: \_\_\_\_\_ Stage Place: \_\_\_\_\_  
 High Hit Factor: \_\_\_\_\_ HHF Shot by: \_\_\_\_\_

Stage 10  
**Any Place**  
 Frank Thompson - CRO

**Stage Designer:** Nationals Design Team  
**Scoring Method:** Comstock  
**Targets:** 6 IPSC, 3 PP – Best 2/paper, Steel: 1 KD = 1 “A”  
**Rounds/Points:** 15 rounds, 75 points  
**Start/Stop:** Audible - Last Shot

**Penalties:**  
 Per current edition of USPSA Rule Book.

**Start Position:**  
 Standing in box with wrists above respective shoulders, gun loaded in ready condition and holstered.

**Procedure:**  
 Upon start signal, engage all targets as visible from the area indicated.

**Notes:**  
 PP1 activates double gravity turner T3, which disappears. PP3 activates drop-out target T5.

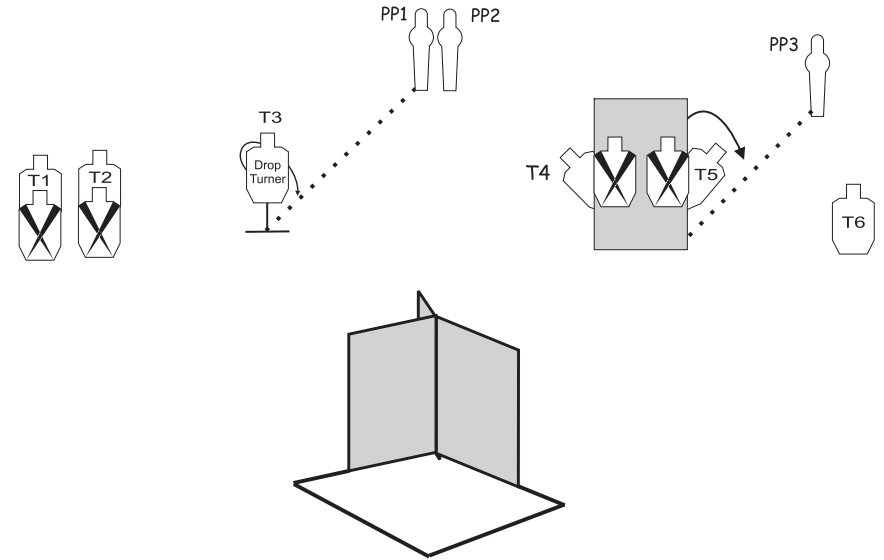

**PERSONAL STAGE DATA**

Points: \_\_\_\_\_ Stage Points: \_\_\_\_\_  
 Time: \_\_\_\_\_ Stage Percent: \_\_\_\_\_  
 Hit Factor: \_\_\_\_\_ Stage Place: \_\_\_\_\_  
 High Hit Factor: \_\_\_\_\_ HHF Shot by: \_\_\_\_\_

Stage II  
**Park Bench**  
 Paul Hernandez - CRO

**Stage Designer:** Nationals Design Team  
**Scoring Method:** Comstock  
**Targets:** 6 IPSC, 2 PP – Best 2/paper, Steel: 1 KD = 1 "A"  
**Rounds/Points:** 14 rounds, 70 points  
**Start/Stop:** Audible - Last Shot

**Penalties:**  
 Per current edition of USPSA Rule Book.

**Start Position:**  
 Sitting on park bench, gun loaded in ready condition placed on X on park bench.

**Procedure:**  
 Upon start signal, engage all targets as visible from the area indicated.

**Notes:**  
 PP1 Activates 360 spinner T4 & T5.

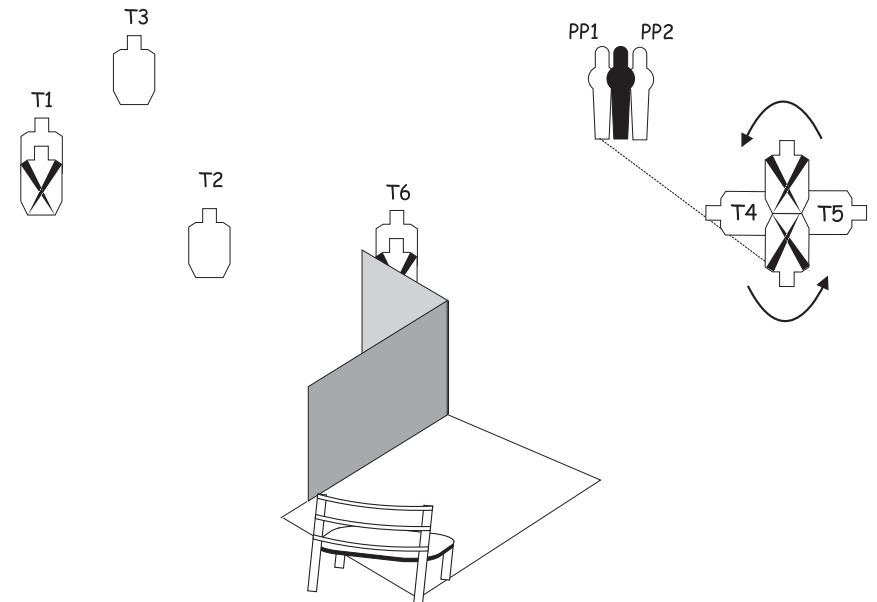

**PERSONAL STAGE DATA**

Points: \_\_\_\_\_ Stage Points: \_\_\_\_\_  
 Time: \_\_\_\_\_ Stage Percent: \_\_\_\_\_  
 Hit Factor: \_\_\_\_\_ Stage Place: \_\_\_\_\_  
 High Hit Factor: \_\_\_\_\_ HHF Shot by: \_\_\_\_\_

Stage 12  
**Bridge Beam**  
 Ray Abernathy - CRO

**Stage Designer:** Nationals Design Team  
**Scoring Method:** Comstock  
**Targets:** 9 IPSC, 5 PP – Best 2/paper, Steel: 1 KD = 1 "A"  
**Rounds/Points:** 23 rounds, 115 points  
**Start/Stop:** Audible - Last Shot

**Penalties:**  
 Per current edition of USPSA Rule Book.

**Start Position:**  
 Heels at end of beam, wrists above respective shoulders, gun loaded in ready condition and holstered.

**Procedure:**  
 Upon start signal, engage all targets as visible while remaining on beam.

**Notes:**  
 PP2 activates gravity turner T3 which disappears. PP3 activates swinger T5.

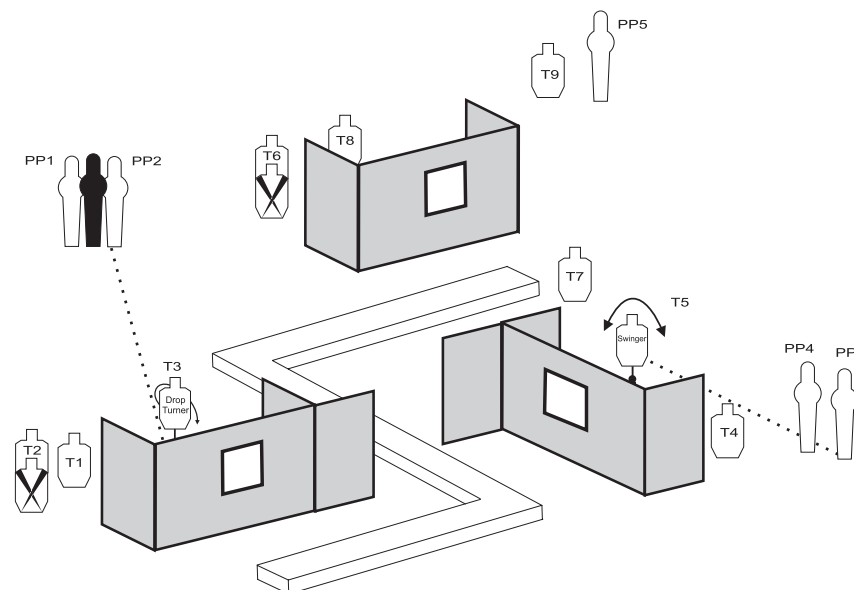

**PERSONAL STAGE DATA**

Points: \_\_\_\_\_ Stage Points: \_\_\_\_\_  
 Time: \_\_\_\_\_ Stage Percent: \_\_\_\_\_  
 Hit Factor: \_\_\_\_\_ Stage Place: \_\_\_\_\_  
 High Hit Factor: \_\_\_\_\_ HHF Shot by: \_\_\_\_\_

Stage 13  
**Triple Play**  
 Charles Varnold - CRO

**Stage Designer:** Nationals Design Team  
**Scoring Method:** Comstock  
**Targets:** 3 IPSC, 2 PP – Best 2/paper, Steel: 1 KD = 1 "A"  
**Rounds/Points:** 8 rounds, 40 points  
**Start/Stop:** Audible - Last Shot

**Penalties:**  
 Per current edition of USPSA Rule Book.

**Start Position:**  
 Standing in box, hands naturally at sides, gun loaded in ready condition and holstered.

**Procedure:**  
 Upon start signal, engage all targets as visible from the area indicated.

**Notes:**  
 PP1 or PP2 activates gravity turner T1. T1 activates gravity turner T2. T2 activates gravity turner T3. T1 and T2 are disappearing. T3 stays visible.

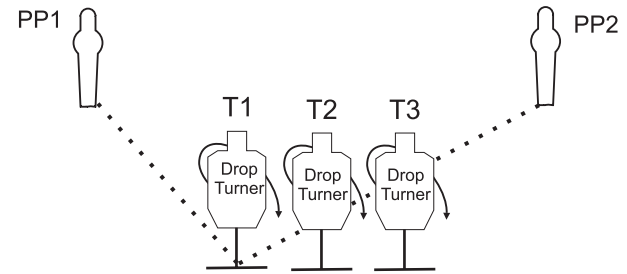

**PERSONAL STAGE DATA**

Points: \_\_\_\_\_ Stage Points: \_\_\_\_\_  
 Time: \_\_\_\_\_ Stage Percent: \_\_\_\_\_  
 Hit Factor: \_\_\_\_\_ Stage Place: \_\_\_\_\_  
 High Hit Factor: \_\_\_\_\_ HHF Shot by: \_\_\_\_\_

Stage 14  
**Beep Beep**  
 Joel Dix - CRO

**Stage Designer:** Nationals Design Team  
**Scoring Method:** Comstock  
**Targets:** 12 IPSC, 4 PP – Best 2/paper, Steel: 1 KD = 1 "A"  
**Rounds/Points:** 28 rounds, 140 points  
**Start/Stop:** Audible - Last Shot

**Penalties:**  
 Per current edition of USPSA Rule Book.

**Start Position:**  
 Sitting in front seat of car, mags and unloaded gun in shooting bag in back seat.

**Procedure:**  
 Upon start signal, engage all targets as visible from the area indicated.

**Notes:**  
 PP1 activates 360 Spinner T5 & T6. PP3 activates drop-out T8.

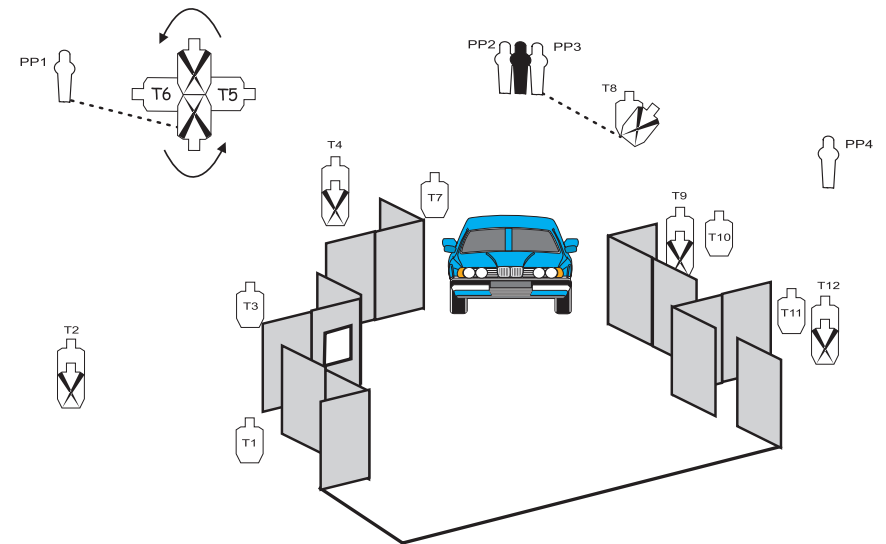

**PERSONAL STAGE DATA**

Points: \_\_\_\_\_ Stage Points: \_\_\_\_\_  
 Time: \_\_\_\_\_ Stage Percent: \_\_\_\_\_  
 Hit Factor: \_\_\_\_\_ Stage Place: \_\_\_\_\_  
 High Hit Factor: \_\_\_\_\_ HHF Shot by: \_\_\_\_\_

# Stage 15 Chamber Check

Perry Wilson - CRO

**Stage Designer:** Nationals Design Team  
**Scoring Method:** Comstock  
**Targets:** 8 IPSC, 1 PP, 5 USP – Best 2/paper, Steel: 1 KD = 1 "A"  
**Rounds/Points:** 22 rounds, 110 points  
**Start/Stop:** Audible - Last Shot

**Penalties:**  
 Per current edition of USPSA Rule Book.

**Start Position:**  
 Toes on marks, hands naturally at sides, gun loaded and holstered with magazine inserted, chamber empty.

**Procedure:**  
 Upon start signal, engage all targets as visible from the area indicated.

**Notes:**  
 PP1 activates Swingers T3 & T7. T5 is a low target.

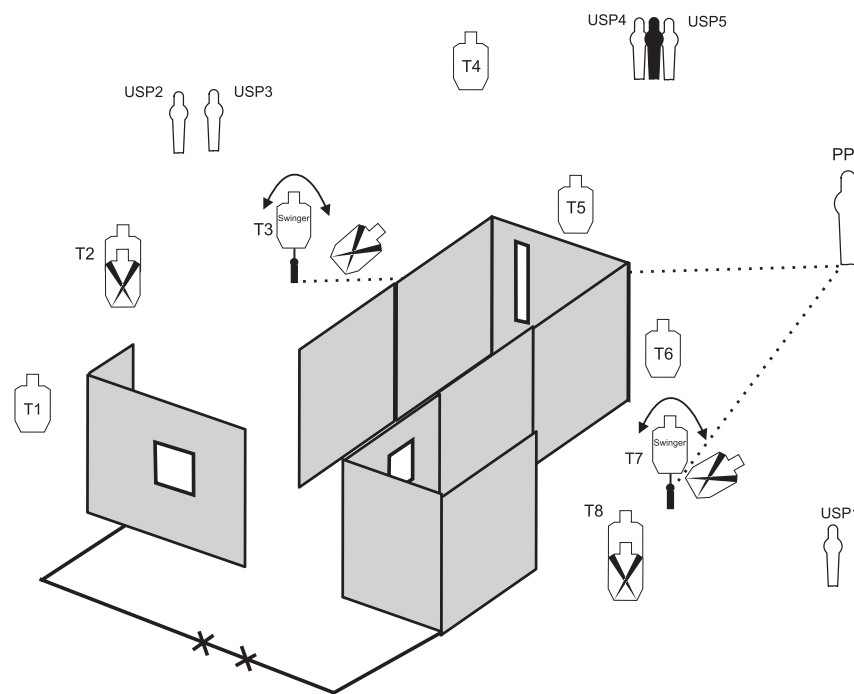

## PERSONAL STAGE DATA

Points: \_\_\_\_\_ Stage Points: \_\_\_\_\_  
 Time: \_\_\_\_\_ Stage Percent: \_\_\_\_\_  
 Hit Factor: \_\_\_\_\_ Stage Place: \_\_\_\_\_  
 High Hit Factor: \_\_\_\_\_ HHF Shot by: \_\_\_\_\_

Stage 16  
**Two Door Sedan**  
 David Hyden - CRO

**Stage Designer:** Nationals Design Team  
**Scoring Method:** Comstock  
**Targets:** 13 IPSC, 5 PP – Best 2/paper, Steel: 1 KD = 1 "A"  
**Rounds/Points:** 31 rounds, 155 points  
**Start/Stop:** Audible - Last Shot

**Penalties:**  
 Per current edition of USPSA Rule Book.

**Start Position:**  
 Both hands on door, gun loaded in ready condition and holstered.

**Procedure:**  
 Upon start signal, engage all targets as visible from the area indicated.

**Notes:**  
 Opening door activates Max Trap T3. Trip box activates Max Trap T5. PP2 activates swinger T6. PP5 activates double gravity turner T12, which disappears.

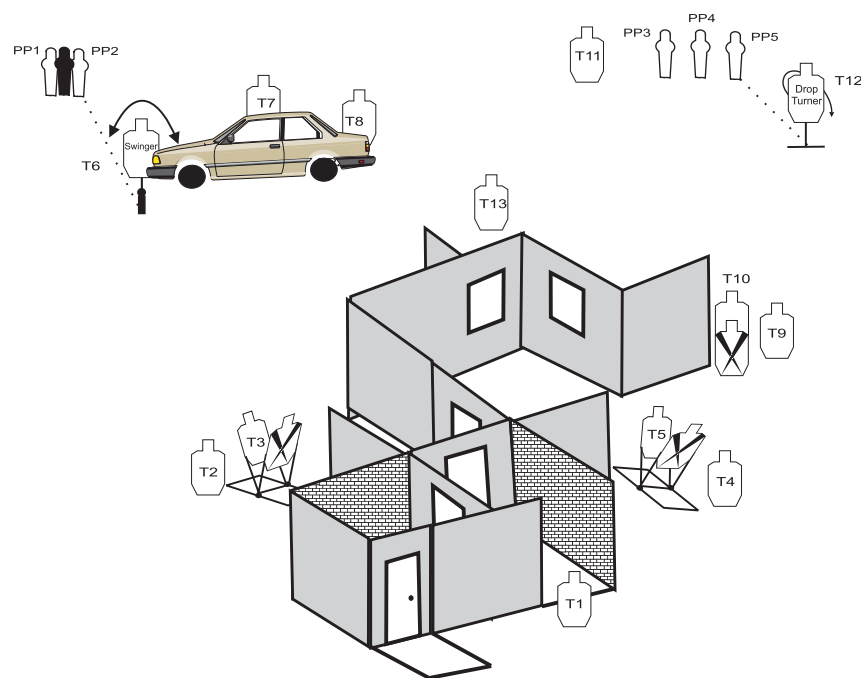

**PERSONAL STAGE DATA**

Points: \_\_\_\_\_ Stage Points: \_\_\_\_\_  
 Time: \_\_\_\_\_ Stage Percent: \_\_\_\_\_  
 Hit Factor: \_\_\_\_\_ Stage Place: \_\_\_\_\_  
 High Hit Factor: \_\_\_\_\_ HHF Shot by: \_\_\_\_\_

Stage 17  
**Bedtime For Bonzo**

Brian Hanna - CRO

**Stage Designer:** Nationals Design Team  
**Scoring Method:** Comstock  
**Targets:** 11 IPSC Classic, 5 PP – Best 2/paper, Steel: 1 KD = 1 "A"  
**Rounds/Points:** 27 rounds, 135 points  
**Start/Stop:** Audible - Last Shot

**Penalties:**  
 Per current edition of USPSA Rule Book.

**Start Position:**  
 Lying flat on bed, gun loaded in ready condition on night stand.

**Procedure:**  
 Upon start signal, engage all targets as visible from the area indicated.

**Notes:**  
 PP5 activates movers T10 & T11 which are disappearing targets.

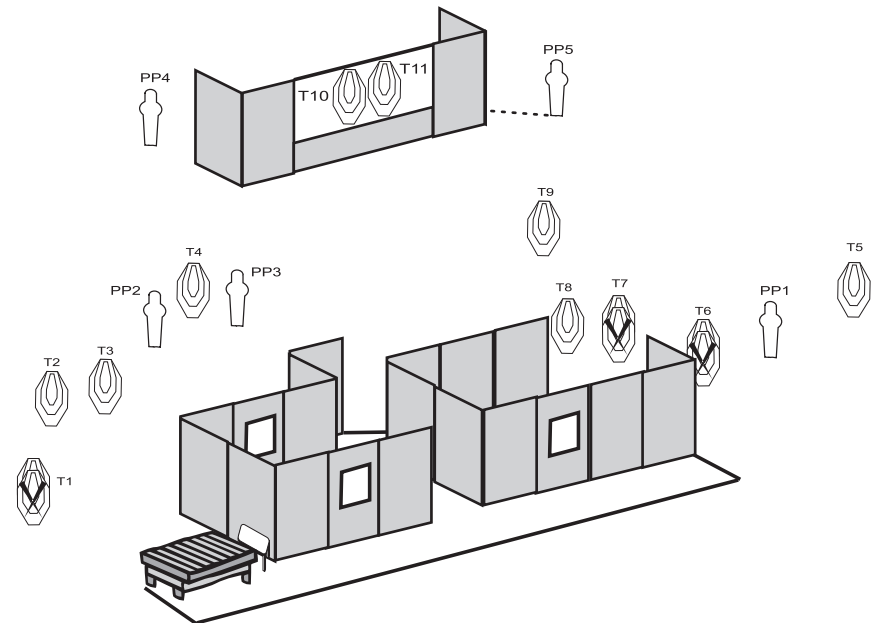

**PERSONAL STAGE DATA**

Points: \_\_\_\_\_ Stage Points: \_\_\_\_\_  
 Time: \_\_\_\_\_ Stage Percent: \_\_\_\_\_  
 Hit Factor: \_\_\_\_\_ Stage Place: \_\_\_\_\_  
 High Hit Factor: \_\_\_\_\_ HHF Shot by: \_\_\_\_\_

# Stage 18

## Upside Down & Sideways

Duane Eggers - CRO

**Stage Designer:** Nationals Design Team  
**Scoring Method:** Comstock  
**Targets:** 9 IPSC, 4 PP – Best 2/paper, Steel: 1 KD = 1 "A"  
**Rounds/Points:** 22 rounds, 110 points  
**Start/Stop:** Audible - Last Shot

**Penalties:**  
 Per current edition of USPSA Rule Book.

**Start Position:**  
 Heels on marks, hands naturally at sides, gun loaded in ready condition and holstered.

**Procedure:**  
 Upon start signal, engage all targets as visible from the area indicated.

**Notes:**  
 PP3 activates side swinger T3. PP4 activates side swinger T5. PP3 or PP4 activates reverse swinger T4.

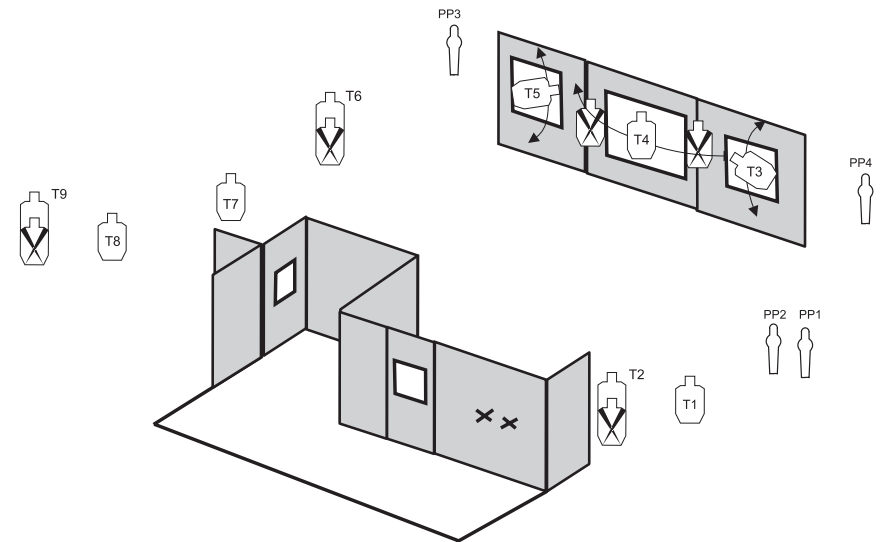

### PERSONAL STAGE DATA

Points: \_\_\_\_\_ Stage Points: \_\_\_\_\_  
 Time: \_\_\_\_\_ Stage Percent: \_\_\_\_\_  
 Hit Factor: \_\_\_\_\_ Stage Place: \_\_\_\_\_  
 High Hit Factor: \_\_\_\_\_ HHF Shot by: \_\_\_\_\_