

Stage I  
**Still A Dark House**  
Jay Worden - CRO

**Stage Designer:** Nationals Design Team  
**Scoring Method:** Comstock  
**Targets:** 6 IPSC – Best 2/paper  
**Rounds/Points:** 12 rounds, 60 points  
**Start/Stop:** Audible - Last Shot

**Penalties:**  
Per current edition of USPSA Rule Book.

**Start Position:**  
Sitting in chair, hands on knees, flashlight on wrist, gun loaded in ready condition and holstered.

**Procedure:**  
Upon start signal, engage all targets as visible.

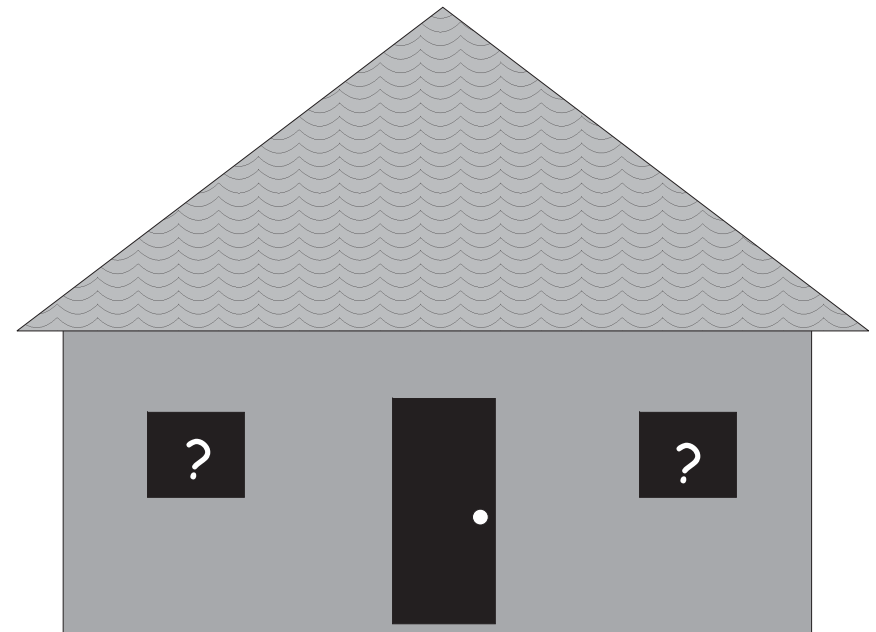

**PERSONAL STAGE DATA**

Points: \_\_\_\_\_ Stage Points: \_\_\_\_\_  
Time: \_\_\_\_\_ Stage Percent: \_\_\_\_\_  
Hit Factor: \_\_\_\_\_ Stage Place: \_\_\_\_\_  
High Hit Factor: \_\_\_\_\_ HHF Shot by: \_\_\_\_\_

Stage 2  
**No Rest For The Weary**  
 J.J. Powell - CRO

<b>Stage Designer:</b>	Nationals Design Team
<b>Scoring Method:</b>	Comstock
<b>Targets:</b>	8 IPSC, 6 PP – Best 2/paper, Steel 1 KD = 1 "A"
<b>Rounds/Points:</b>	22 rounds, 110 points
<b>Start/Stop:</b>	Audible - Last Shot
<b>Penalties:</b>	Per current edition of USPSA Rule Book.
<b>Start Position:</b>	Lying flat on bed, heels resting on bed, hands covering eyes, gun loaded in ready condition and on table.
<b>Procedure:</b>	Upon start signal, engage all targets as visible.
<b>Notes:</b>	PP1 activates Swinger T3.

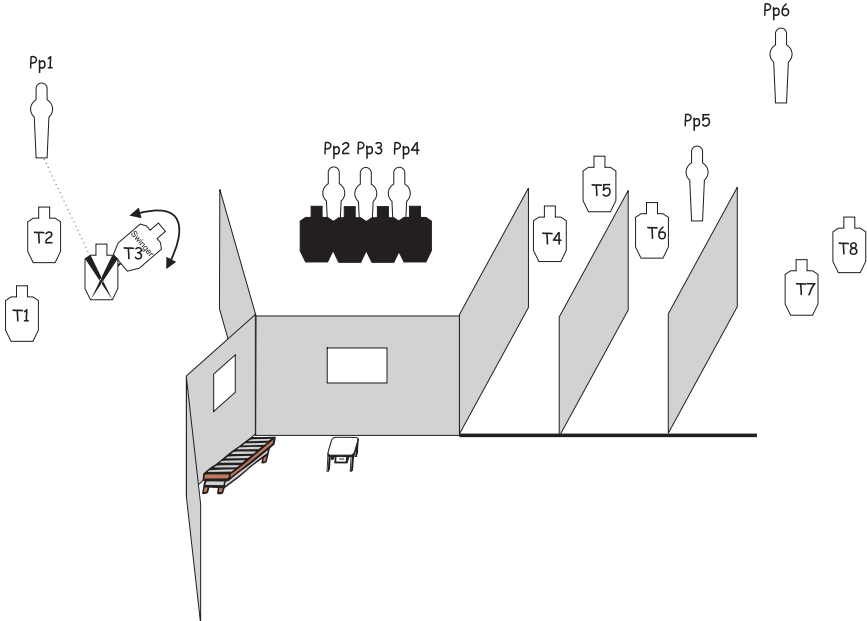

**PERSONAL STAGE DATA**

Points: \_\_\_\_\_ Stage Points: \_\_\_\_\_

Time: \_\_\_\_\_ Stage Percent: \_\_\_\_\_

Hit Factor: \_\_\_\_\_ Stage Place: \_\_\_\_\_

High Hit Factor: \_\_\_\_\_ HHF Shot by: \_\_\_\_\_

Stage 3  
**The Two Step**  
 Bill Quintana - CRO

**Stage Designer:** Jim Kosicki - modifications by Nationals Design Team  
**Scoring Method:** Comstock  
**Targets:** 6 IPSC, 2 PP, 1 USP – Best 2/paper Steel: 1 KD = 1 "A"  
**Rounds/Points:** 15 rounds, 75 points  
**Start/Stop:** Audible - Last Shot

**Penalties:**  
 Per current edition of USPSA Rule Book.

**Start Position:**  
 Toes on X's, hands at sides, gun loaded in ready condition and holstered.

**Procedure:**  
 Upon start signal, engage all targets as visible from within fault lines.

**Note:**  
 PP2 activates Swinger T4.

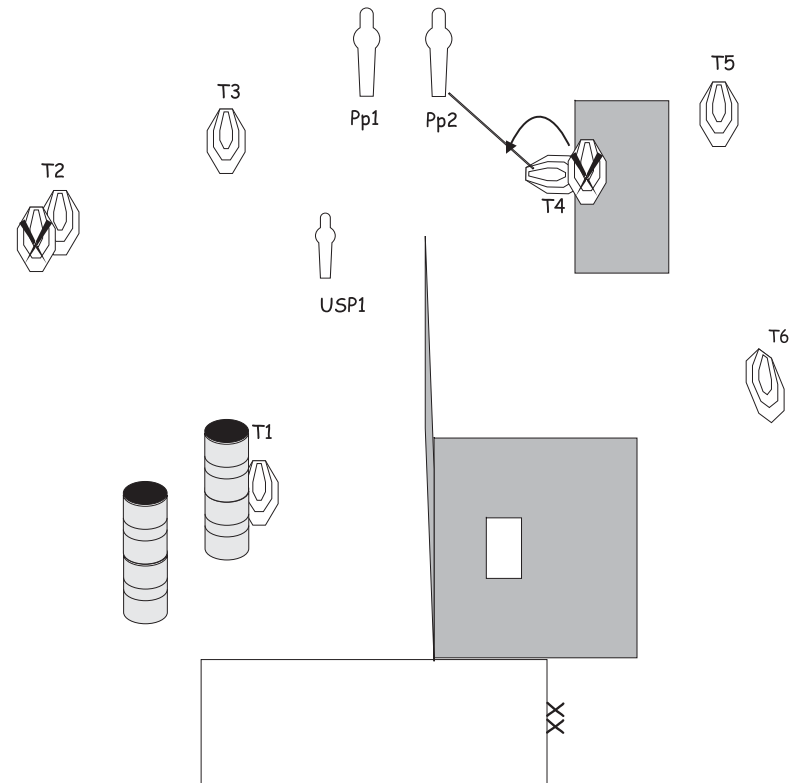

**PERSONAL STAGE DATA**

Points: \_\_\_\_\_ Stage Points: \_\_\_\_\_  
 Time: \_\_\_\_\_ Stage Percent: \_\_\_\_\_  
 Hit Factor: \_\_\_\_\_ Stage Place: \_\_\_\_\_  
 High Hit Factor: \_\_\_\_\_ HHF Shot by: \_\_\_\_\_

Stage 4  
**Big Barricade II**

Angelo Rodriguez - CRO

**Stage Designer:** Nationals Design Team  
**Scoring Method:** Comstock  
**Targets:** 6 IPSC, 4 USP – Best 2/paper, Steel: 1 KD = 1 "A"  
**Rounds/Points:** 16 rounds, 80 points  
**Start/Stop:** Audible - Last Shot

**Penalties:**  
 Per current edition of USPSA Rule Book.

**Start Position:**  
 Standing behind barricade, hands on X's, gun loaded in ready condition and holstered.

**Procedure:**  
 Upon start signal, engage all targets as visible.

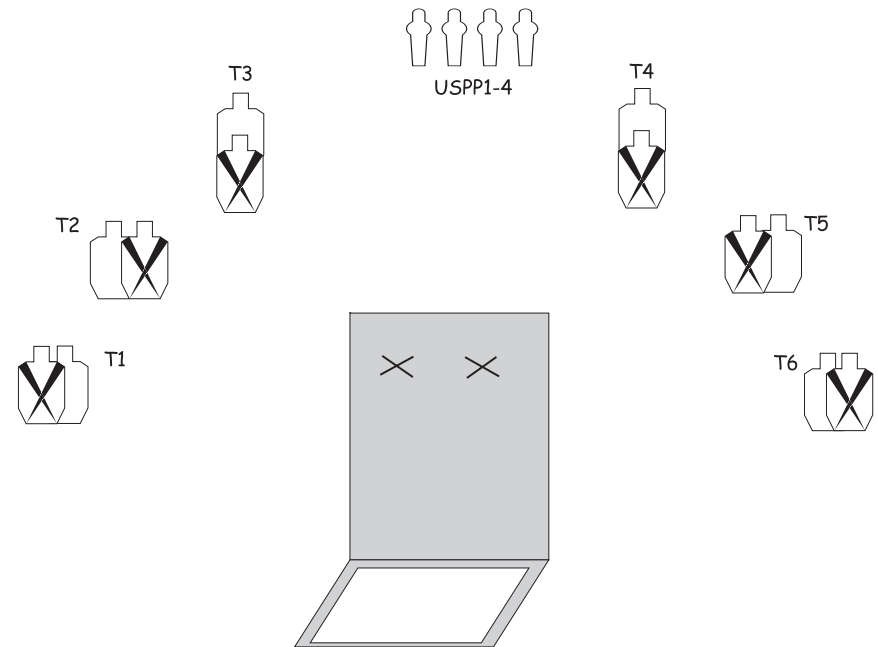

**PERSONAL STAGE DATA**

Points: \_\_\_\_\_ Stage Points: \_\_\_\_\_  
 Time: \_\_\_\_\_ Stage Percent: \_\_\_\_\_  
 Hit Factor: \_\_\_\_\_ Stage Place: \_\_\_\_\_  
 High Hit Factor: \_\_\_\_\_ HHF Shot by: \_\_\_\_\_

Stage 5  
**In The Zone**  
 Frank Thompson - CRO

<b>Stage Designer:</b>	Nationals Design Team
<b>Scoring Method:</b>	Comstock
<b>Targets:</b>	6 IPSC, 4 PP – Best 2/paper, Steel-1 KD = 1 "A"
<b>Rounds/Points:</b>	16 rounds, 80 points
<b>Start/Stop:</b>	Audible - Last Shot
<b>Penalties:</b>	Per current edition of USPSA Rule Book.
<b>Start Position:</b>	Sitting at chair, hands on knees, gun loaded in ready condition and holstered.
<b>Procedure:</b>	Upon start signal, engage all targets as visible.
<b>Notes:</b>	PP3 activates Gravity turner T6.

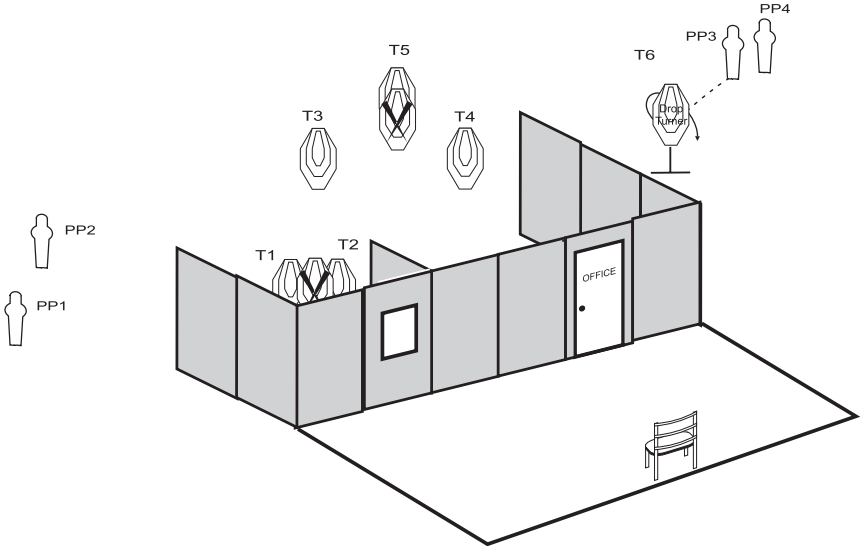

**PERSONAL STAGE DATA**

Points: \_\_\_\_\_ Stage Points: \_\_\_\_\_

Time: \_\_\_\_\_ Stage Percent: \_\_\_\_\_

Hit Factor: \_\_\_\_\_ Stage Place: \_\_\_\_\_

High Hit Factor: \_\_\_\_\_ HHF Shot by: \_\_\_\_\_

Stage 6  
**One For The Lefties**

Ken Kempker - CRO

**Stage Designer:** Nationals Design Team  
**Scoring Method:** Comstock  
**Targets:** 12 IPSC, 3 PP – Best 2/paper Steel: 1 KD = 1 "A"  
**Rounds/Points:** 27 rounds, 135 points  
**Start/Stop:** Audible - Last Shot

**Penalties:**  
 Per current edition of USPSA Rule Book.

**Start Position:**  
 Palms on X's, gun loaded in ready condition and holstered.

**Procedure:**  
 Upon start signal, engage all targets as visible.

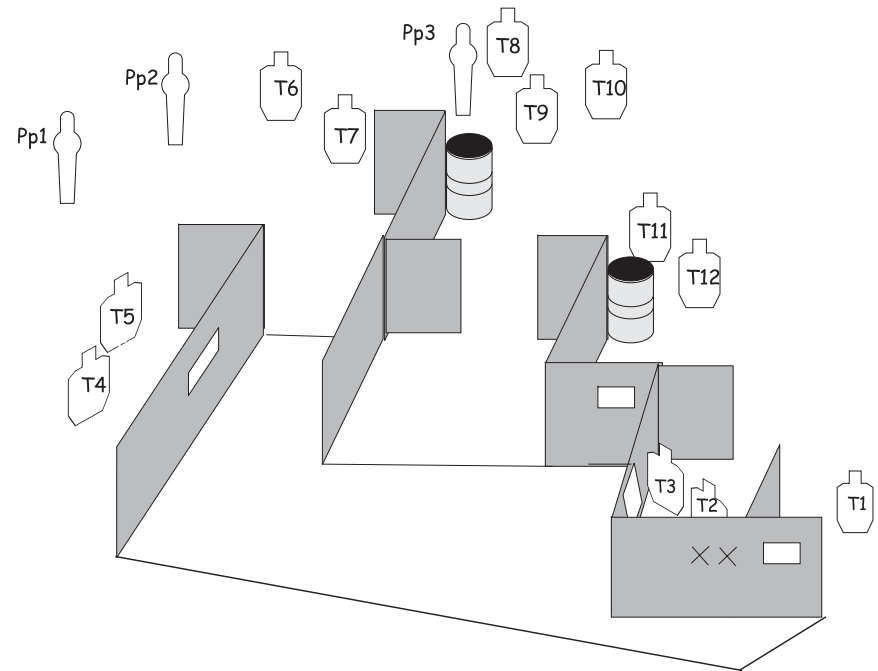

**PERSONAL STAGE DATA**

Points: \_\_\_\_\_ Stage Points: \_\_\_\_\_  
 Time: \_\_\_\_\_ Stage Percent: \_\_\_\_\_  
 Hit Factor: \_\_\_\_\_ Stage Place: \_\_\_\_\_  
 High Hit Factor: \_\_\_\_\_ HHF Shot by: \_\_\_\_\_

Stage 7  
**Comstock Barricade**  
 Bob Clift - CRO

<b>Stage Designer:</b>	Paul Clarke – modifications by Nationals Design Team
<b>Scoring Method:</b>	Comstock
<b>Targets:</b>	4 IPSC, 2 PP – Best 2/paper, Steel: 1 KD = 1 "A"
<b>Rounds/Points:</b>	10 rounds, 50 points
<b>Start/Stop:</b>	Audible - Last Shot
<b>Penalties:</b>	Per current edition of USPSA Rule Book.
<b>Start Position:</b>	Standing in Bianchi barricade box, hands on X's, gun loaded in ready condition and holstered.
<b>Procedure:</b>	Upon start signal, engage all targets as visible from within barricade box.
<b>Note:</b>	PP1 activates Swinger T2.

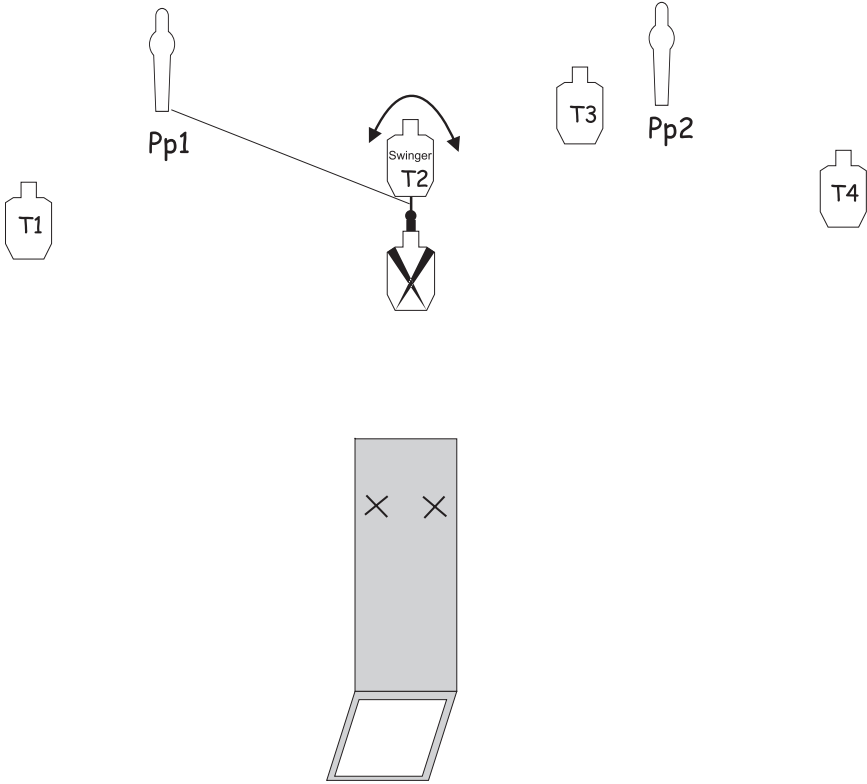

**PERSONAL STAGE DATA**

Points: \_\_\_\_\_ Stage Points: \_\_\_\_\_

Time: \_\_\_\_\_ Stage Percent: \_\_\_\_\_

Hit Factor: \_\_\_\_\_ Stage Place: \_\_\_\_\_

High Hit Factor: \_\_\_\_\_ HHF Shot by: \_\_\_\_\_

Stage 8  
**Steely Speed VII**

Bob Clift - CRO

**Stage Designer:** Nationals Design Team  
**Scoring Method:** Comstock  
**Targets:** 3 PP, 3 USP – Steel: 1 KD = 1 "A"  
**Rounds/Points:** 6 rounds, 30 points  
**Start/Stop:** Audible - Last Shot

**Penalties:**  
 Per current edition of USPSA Rule Book.

**Start Position:**  
 Standing behind barricade, hands on X's, gun loaded and holstered in ready condition.

**Procedure:**  
 Upon start signal, engage all targets as visible.

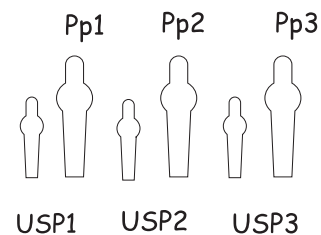

**PERSONAL STAGE DATA**

Points: \_\_\_\_\_ Stage Points: \_\_\_\_\_  
 Time: \_\_\_\_\_ Stage Percent: \_\_\_\_\_  
 Hit Factor: \_\_\_\_\_ Stage Place: \_\_\_\_\_  
 High Hit Factor: \_\_\_\_\_ HHF Shot by: \_\_\_\_\_

Stage 9  
**Up And Down**  
 Paul Hernandez - CRO

**Stage Designer:** Nationals Design Team  
**Scoring Method:** Comstock  
**Targets:** 8 IPSC, 2 PP – Best 2/paper, Steel-1 KD = 1 “A”  
**Rounds/Points:** 18 rounds, 90 points  
**Start/Stop:** Audible - Last Shot

**Penalties:**  
 Per current edition of USPSA Rule Book.

**Start Position:**  
 Standing facing house, heels on start line, hands naturally at sides, gun loaded in ready condition and holstered.

**Procedure:**  
 Upon start signal, enter house and engage all targets as visible.

**Notes:**  
 PP1 and PP2 activate bobbing target T1.

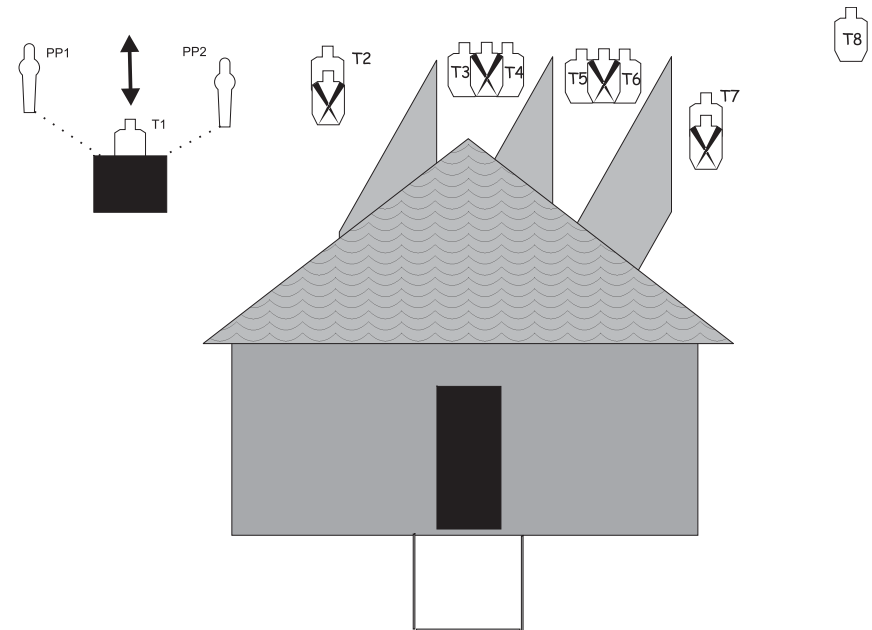

**PERSONAL STAGE DATA**

Points: \_\_\_\_\_ Stage Points: \_\_\_\_\_  
 Time: \_\_\_\_\_ Stage Percent: \_\_\_\_\_  
 Hit Factor: \_\_\_\_\_ Stage Place: \_\_\_\_\_  
 High Hit Factor: \_\_\_\_\_ HHF Shot by: \_\_\_\_\_

# Stage 10

## Passing Through

Duane Eggers - CRO

**Stage Designer:** Nationals Design Team  
**Scoring Method:** Comstock  
**Targets:** 7 IPSC, 2 PP – Best 2/paper, Steel: 1 KD = 1 "A"  
**Rounds/Points:** 16 rounds, 80 points  
**Start/Stop:** Audible - Last Shot

**Penalties:**  
 Per current edition of USPSA Rule Book.

**Start Position:**  
 Standing with hands naturally at sides, heels touching back fault line, gun loaded in ready condition and holstered.

**Procedure:**  
 Upon start signal, engage all targets as visible.

**Notes:**  
 PP1 activates Gravity Turner T5.  
 PP2 activates Swinger T7.

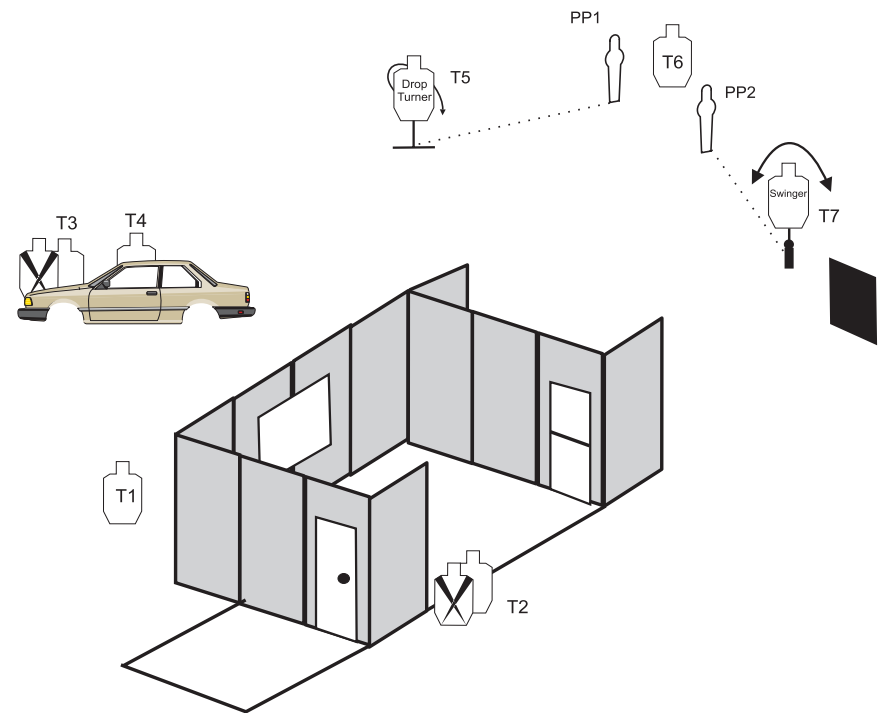

### PERSONAL STAGE DATA

Points: \_\_\_\_\_ Stage Points: \_\_\_\_\_  
 Time: \_\_\_\_\_ Stage Percent: \_\_\_\_\_  
 Hit Factor: \_\_\_\_\_ Stage Place: \_\_\_\_\_  
 High Hit Factor: \_\_\_\_\_ HHF Shot by: \_\_\_\_\_

Stage II  
**Knock Knock**  
 Ed Putnam - CRO

**Stage Designer:** Nationals Design Team  
**Scoring Method:** Comstock  
**Targets:** 7 IPSC, 2 PP – Best 2/paper, Steel--1 KD = 1 "A"  
**Rounds/Points:** 16 rounds, 80 points  
**Start/Stop:** Audible - Last Shot

**Penalties:**  
 Per current edition of USPSA Rule Book.

**Start Position:**  
 Heels on X's, gun loaded in ready condition and holstered.

**Procedure:**  
 Upon start signal, engage all targets as visible.

**Notes:**  
 PP1 activates Gravity Turner T7.  
 Opening left door activates Max Trap T4.  
 Opening right door activates Max Trap T5.

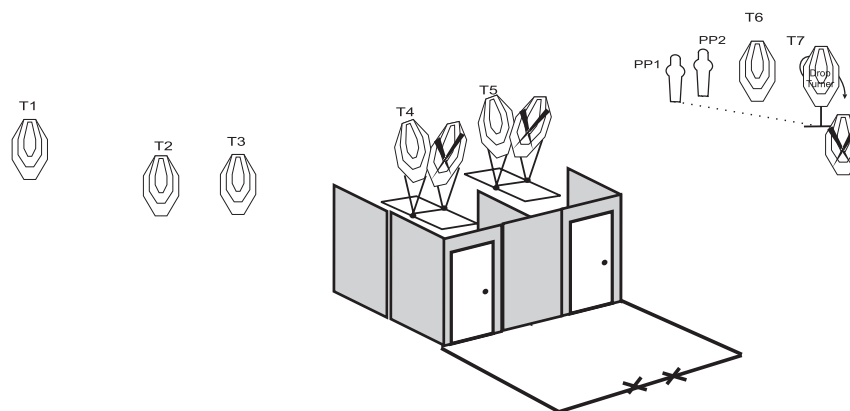

**PERSONAL STAGE DATA**

Points: \_\_\_\_\_ Stage Points: \_\_\_\_\_  
 Time: \_\_\_\_\_ Stage Percent: \_\_\_\_\_  
 Hit Factor: \_\_\_\_\_ Stage Place: \_\_\_\_\_  
 High Hit Factor: \_\_\_\_\_ HHF Shot by: \_\_\_\_\_

Stage 12  
**Not In My Yard**

Brian Hanna - CRO

**Stage Designer:** Nationals Design Team  
**Scoring Method:** Comstock  
**Targets:** 10 IPSC, 1 PP – Best 2/paper, Steel: 1 KD = 1 "A"  
**Rounds/Points:** 21 rounds, 105 points  
**Start/Stop:** Audible - Last Shot

**Penalties:**  
 Per current edition of USPSA Rule Book.

**Start Position:**  
 Palms on marks, gun loaded in ready condition and holstered.

**Procedure:**  
 Upon start signal, engage all targets as visible.

**Notes:**  
 PP1 activates Drop Turner T9.

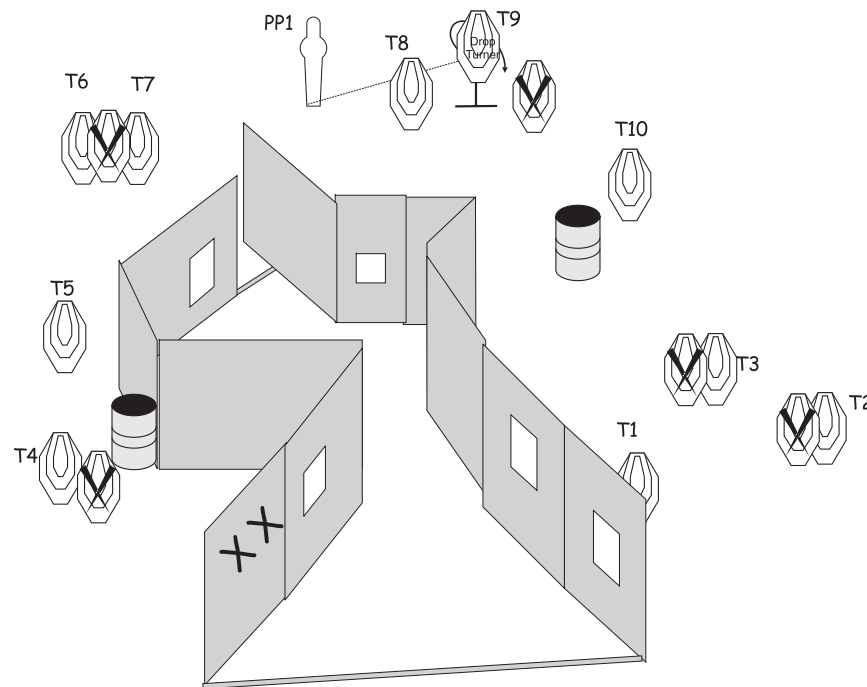

**PERSONAL STAGE DATA**

Points: \_\_\_\_\_ Stage Points: \_\_\_\_\_  
 Time: \_\_\_\_\_ Stage Percent: \_\_\_\_\_  
 Hit Factor: \_\_\_\_\_ Stage Place: \_\_\_\_\_  
 High Hit Factor: \_\_\_\_\_ HHF Shot by: \_\_\_\_\_

Stage 13  
**Where's The Ammo**

Charles Varnold- CRO

**Stage Designer:** Nationals Design Team  
**Scoring Method:** Comstock  
**Targets:** 2 IPSC, 4 USPP – Best 2/paper, Steel-1 KD = 1 "A"  
**Rounds/Points:** 8 rounds, 40 points  
**Start/Stop:** Audible - Last Shot

**Penalties:**  
 Per current edition of USPSA Rule Book.

**Start Position:**  
 Standing, palms flat on table top, gun in empty condition and on table, muzzle pointing downrange

**Procedure:**  
 Upon start signal, retrieve gun and engage all targets as visible.

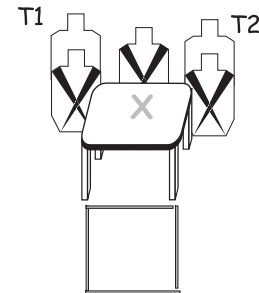
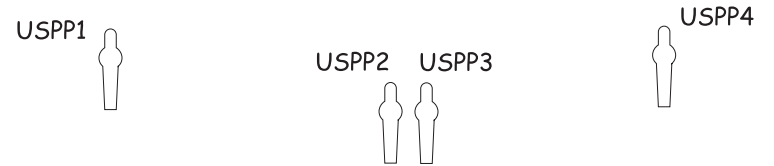

**PERSONAL STAGE DATA**

Points: \_\_\_\_\_ Stage Points: \_\_\_\_\_  
 Time: \_\_\_\_\_ Stage Percent: \_\_\_\_\_  
 Hit Factor: \_\_\_\_\_ Stage Place: \_\_\_\_\_  
 High Hit Factor: \_\_\_\_\_ HHF Shot by: \_\_\_\_\_

Stage 14  
**Yes, That Taxi Again**  
 Deb Hawkins - CRO

**Stage Designer:** Nationals Design Team  
**Scoring Method:** Comstock  
**Targets:** 13 IPSC, 6 PP – Best 2/paper, Steel--1 KD = 1 "A"  
**Rounds/Points:** 32 rounds, 160 points  
**Start/Stop:** Audible - Last Shot

**Penalties:**  
 Per current edition of USPSA Rule Book.

**Start Position:**  
 Palms on X's, gun loaded in ready condition and holstered.

**Procedure:**  
 Upon start signal, engage all targets as visible.

**Notes:**  
 PP1 activates Max Trap T3.  
 PP2 activates Double Gravity Turner T6.  
 PP4 activates Double Gravity Turner T7.  
 PP5 activates Bobber T10.  
 PP6 activates Reverse Swinger T12.

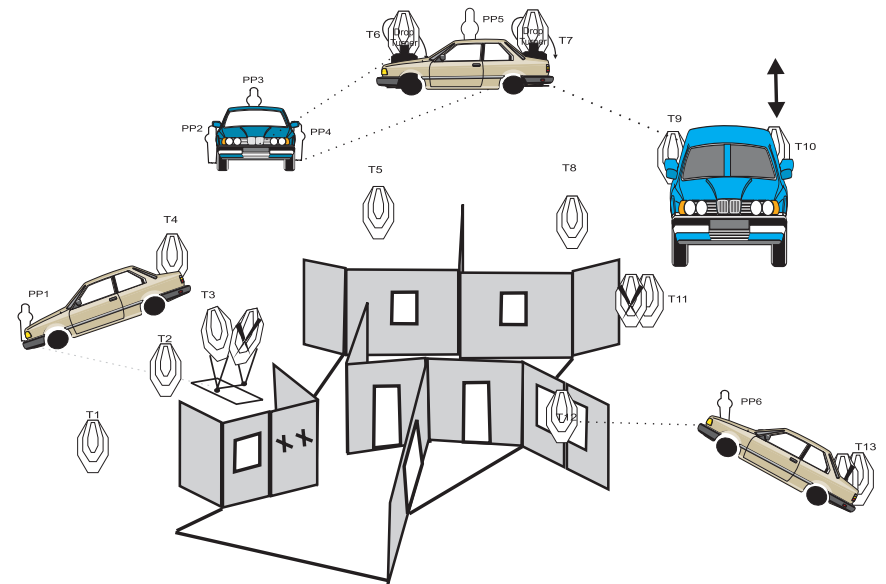

**PERSONAL STAGE DATA**

Points: \_\_\_\_\_ Stage Points: \_\_\_\_\_  
 Time: \_\_\_\_\_ Stage Percent: \_\_\_\_\_  
 Hit Factor: \_\_\_\_\_ Stage Place: \_\_\_\_\_  
 High Hit Factor: \_\_\_\_\_ HHF Shot by: \_\_\_\_\_

Stage 15  
**Hot Seat**  
 Carl Schmidt - CRO

**Stage Designer:** Nationals Design Team  
**Scoring Method:** Comstock  
**Targets:** 9 IPSC, 3 PP – Best 2/paper, Steel--1 KD = 1 "A"  
**Rounds/Points:** 21 rounds, 105 points  
**Start/Stop:** Audible - Last Shot

**Penalties:**  
 Per current edition of USPSA Rule Book.

**Start Position:**  
 Heels on X's, palms on knees, gun loaded in ready condition and holstered.

**Procedure:**  
 Upon start signal, retrieve gun and engage all targets as visible.

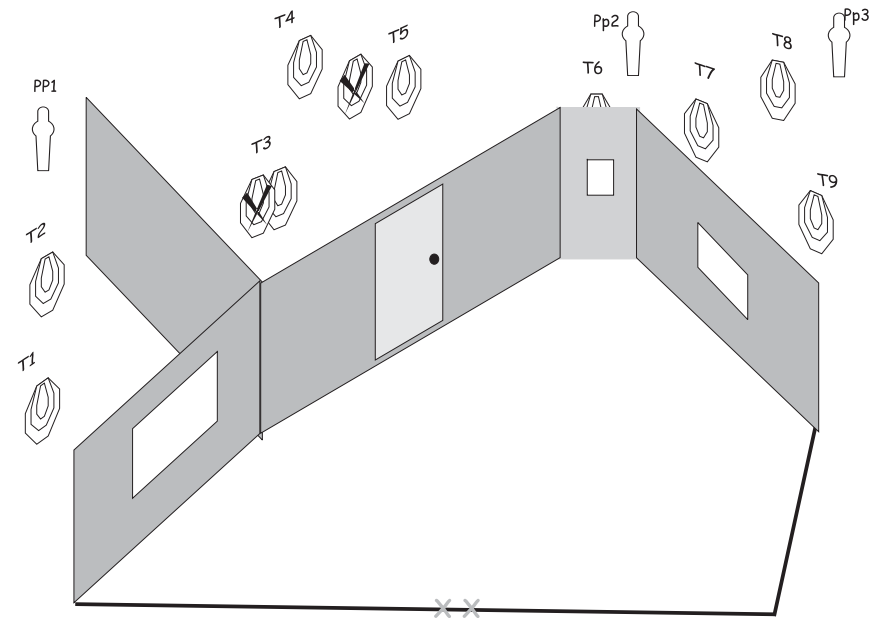

**PERSONAL STAGE DATA**

Points: \_\_\_\_\_ Stage Points: \_\_\_\_\_  
 Time: \_\_\_\_\_ Stage Percent: \_\_\_\_\_  
 Hit Factor: \_\_\_\_\_ Stage Place: \_\_\_\_\_  
 High Hit Factor: \_\_\_\_\_ HHF Shot by: \_\_\_\_\_

Stage 16  
**Behind Door #1**  
 David Hyden - CRO

**Stage Designer:** Nationals Design Team  
**Scoring Method:** Comstock  
**Targets:** 12 IPSC, 4 PP – Best 2/paper, Steel--1 KD = 1 "A"  
**Rounds/Points:** 28 rounds, 140 points  
**Start/Stop:** Audible - Last Shot

**Penalties:**  
 Per current edition of USPSA Rule Book.

**Start Position:**  
 Standing facing downrange, heels on marks, gun loaded and holstered in ready condition.

**Procedure:**  
 Upon start signal, engage all targets as visible.

**Notes:**  
 PP1 activates Swinger T6.

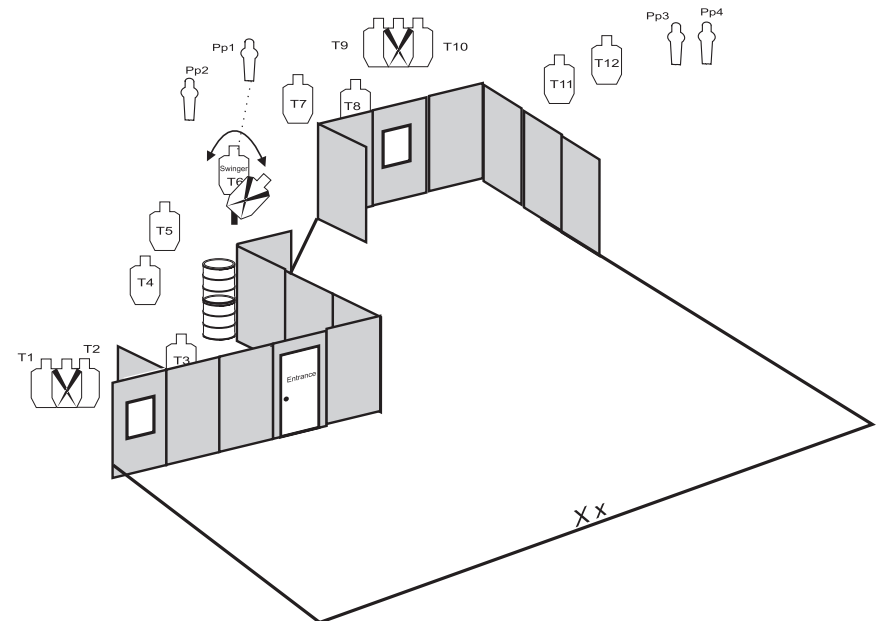

**PERSONAL STAGE DATA**

Points: \_\_\_\_\_ Stage Points: \_\_\_\_\_  
 Time: \_\_\_\_\_ Stage Percent: \_\_\_\_\_  
 Hit Factor: \_\_\_\_\_ Stage Place: \_\_\_\_\_  
 High Hit Factor: \_\_\_\_\_ HHF Shot by: \_\_\_\_\_

Stage 17  
**Moving On Up**  
 Tom Loyd - CRO

**Stage Designer:** Nationals Design Team  
**Scoring Method:** Comstock  
**Targets:** 10 IPSC, 5 PP – Best 2/paper, Steel--1 KD = 1 "A"  
**Rounds/Points:** 25 rounds, 125 points  
**Start/Stop:** Audible - Last Shot

**Penalties:**  
 Per current edition of USPSA Rule Book.

**Start Position:**  
 Standing at door, strong hand holding door knob, gun loaded in ready condition and holstered.

**Procedure:**  
 Upon start signal, engage all targets as visible.

**Notes:**  
 Opening door activates Drop Turner T3.  
 PP3 starts movers T4-T6.  
 PP5 activates Swinger T10.

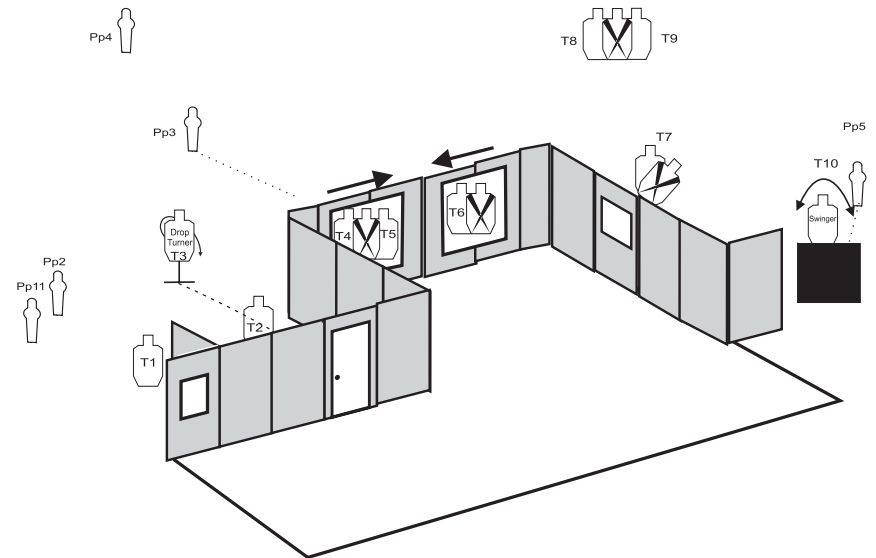

**PERSONAL STAGE DATA**

Points: \_\_\_\_\_ Stage Points: \_\_\_\_\_  
 Time: \_\_\_\_\_ Stage Percent: \_\_\_\_\_  
 Hit Factor: \_\_\_\_\_ Stage Place: \_\_\_\_\_  
 High Hit Factor: \_\_\_\_\_ HHF Shot by: \_\_\_\_\_

Stage 18  
**Your Choice - Get Ur Done**  
 Perry Wilson - CRO

<b>Stage Designer:</b>	Nationals Design Team
<b>Scoring Method:</b>	Comstock
<b>Targets:</b>	7 IPSC, 4 PP – Best 2/paper, Steel: 1 KD = 1 "A"
<b>Rounds/Points:</b>	18 rounds, 90 points
<b>Start/Stop:</b>	Audible - Last Shot
<b>Penalties:</b>	Per current edition of USPSA Rule Book.
<b>Start Position:</b>	Hands on X's on wall, gun loaded in ready condition and holstered.
<b>Procedure:</b>	Upon start signal, enter shooting area and engage all targets as visible.
<b>Notes:</b>	PP1 activates Swinger T5. PP4 activates 360-degree Spinner T1 & T2.

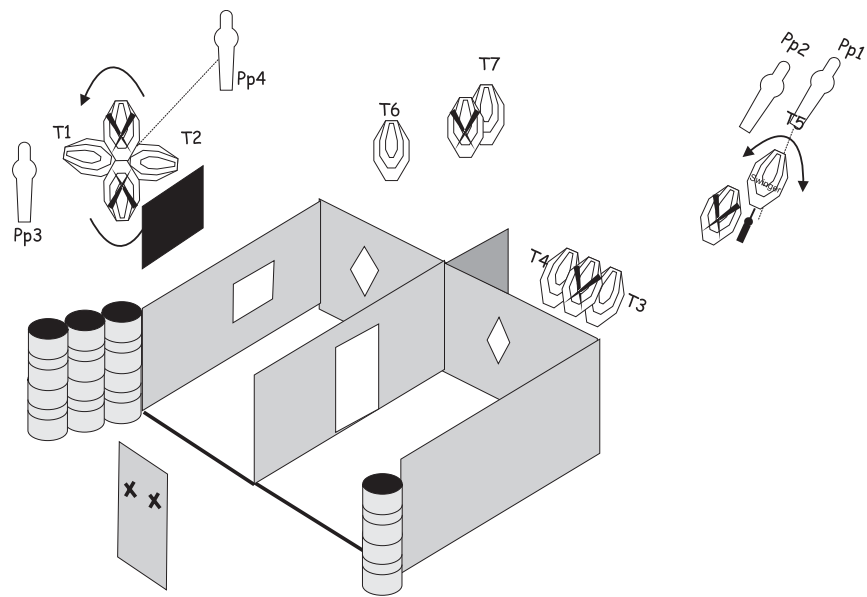

**PERSONAL STAGE DATA**

Points: \_\_\_\_\_ Stage Points: \_\_\_\_\_

Time: \_\_\_\_\_ Stage Percent: \_\_\_\_\_

Hit Factor: \_\_\_\_\_ Stage Place: \_\_\_\_\_

High Hit Factor: \_\_\_\_\_ HHF Shot by: \_\_\_\_\_